



INSTALLATION, OPERATION AND MAINTENANCE MANUAL

SA MODEL ALUMINUM STOP LOG



INDEX

Page

0. Introduction	2
1. Equipment main components.....	3
2. Handling and Storage.....	4
3. Installation	5
3.1. Embedded in concrete (in the channel recess).....	5
3.2. Face mounted (in existing channel without recesses).....	6
3.3. Wall mounted (at the end of the channel).....	8
4. Start-up and commissioning.....	10
5. Operation.....	11
6. Maintenance.....	11
6.1. Cleaning and lubrication.....	11
6.2. Seal replacement: horizontal and bottom seal.....	12
6.3. Seal replacement: vertical seal.....	13
7. Trouble shooting.....	14
8. Annex: civil work tolerances.....	15
9. Environmental considerations.....	16

0. INTRODUCTION

- This manual describes the recommended procedures for installation, operation, maintenance and safety precautions for the following ORBINOX equipment:
 - **SA Aluminum Stop Log**
- Please read thoroughly all the instructions in the manual prior to installation and contact an ORBINOX representative in case of any questions
- The manual makes reference to the “General Arrangement Drawing” (GAD). The GAD is the drawing that is sent to and approved by the customer prior to the production of the stop log. The manual shall be used in conjunction with the GAD
- **ORBINOX assumes no responsibility or liability if the gate is not installed, operated and maintained in strict accordance to the procedures described in this manual**

MODEL

SA ALUMINUM STOP LOG



1. EQUIPMENT MAIN COMPONENTS

ITEM	DESCRIPTION
1	FRAME
2	LOG
3	VERTICAL SEAL
4	BOTTOM SEAL
5	LATERAL GUIDE
6	LOG LOCKING SYSTEM
7	SEAL AND GUIDE LOCKING SYSTEM
8	INTERMEDIATE SEAL

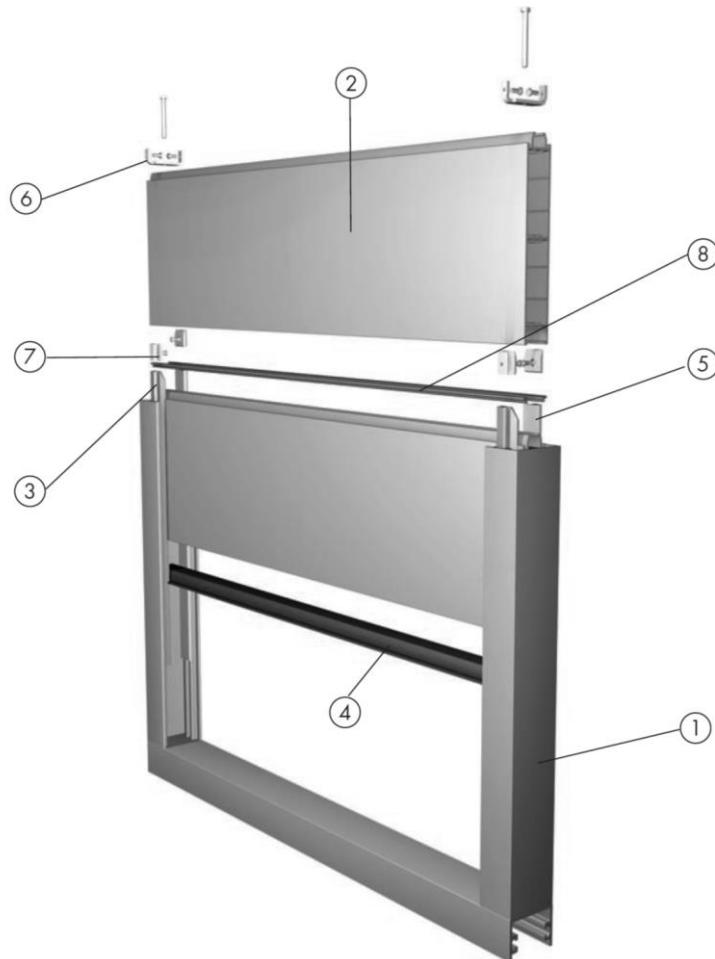

Figure 1: SA Stop Log

2. HANDLING AND STORAGE

Handling

- Standard safety procedures shall be followed to prevent personal injury or equipment damage
- The equipment shall be lifted from the main frame. For bigger gates, the frame comes with hoist rings specially arranged for handling purposes
- Never lift the gates in the inverted position or from the log

Storage

- Check the equipment on delivery and report back to ORBINOX any missing components within 3 days from receipt of the equipment. ORBINOX will not accept responsibility for loss or damage to any equipment which has occurred after this period
- Some gates might be packed with wooden strips (or tensioning steel beams) between both frame guides. Do not remove the strips/beams before the gate has been properly installed in order to avoid any damage or distortion to the frame
- Equipment shall be stored in a dry, clean and even area on a raised even wood surface to prevent distortion of the frame. Do not stack Stop Logs

3. INSTALLATION

- This section describes the different installation methods (See section 3.1 to 3.3). **Please refer to the GAD to identify the installation method that is applicable to the purchased equipment.**
- The concrete construction shall be flat, level and plumb, and shall be in accordance to DIN 18202 or equivalent ACI 117-06 standard (see Section 8). If necessary, use non-shrink grout in order to meet the specified standard. The minimum concrete strength shall be 25 MPa (3,600 PSI)
- The following procedures are general installation guidelines. Please refer to the notes on the GAD for specific information about the installation method and the required materials (type, size and quantity of anchor bolts, construction sealant, etc.). Always follow the anchor bolt and construction sealant manufacturers' installation instructions. Note that, typically, construction sealant requires dry concrete surfaces for its application
- Note that as standard, installation materials such as anchor bolts, hex-bolts and construction sealant are not supplied with the equipment, unless otherwise specified

3.1. Embedded in concrete (in the channel recess)

Step 1: Initial assessment

- Check that the concrete wall meets the requirements described in Section 3
- Verify that all installation materials specified on the GAD are available. Wooden wedges are used to center and level the gate in the recess prior to embedding it in concrete

Step 2: Frame alignment in the recess

- Position and center the unit in the recess of the wall, using wooden wedges
- Align the unit vertically and make sure that the frame is flush with the invert of the channel. The frame includes two threaded holes, which must be used to secure vertical alignment supports (see Figure 3). Note that the supports are not supplied, unless otherwise specified (two metal or wooden plates are required)
- Align the unit horizontally and make sure that the Frame Guide is flush with the channel side wall. Additionally, make sure that the gate is perpendicular to the side walls of the channel (See Figure 3). For aluminum frames, use wooden wedges to center the unit in the recess. As an option, stainless steel frames include "Lateral Centering Fittings". In that case, adjust the hex bolts for centering the frame

Step 3: Frame embedment in the wall recess

- Pour the second phase of concrete. Take special care not to damage the seals (see Figure 4)
- Do not pour in more than one meter concrete columns to avoid damage to the frame
- Remove the frame tensioning top beam if applicable

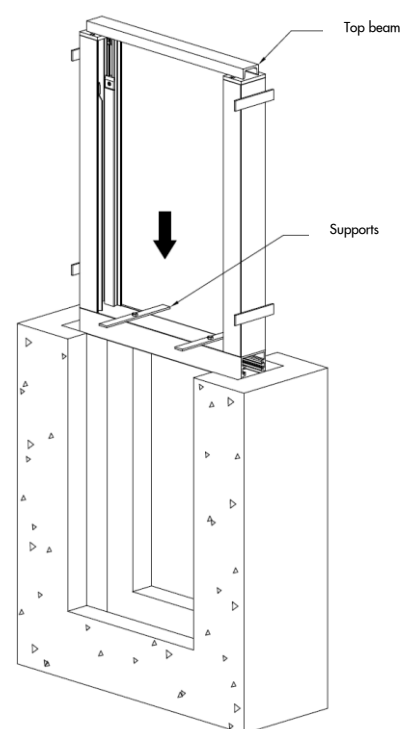

Figure 2

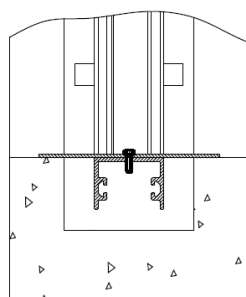

Figure 3

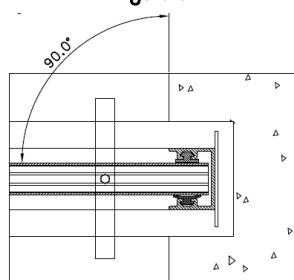

Figure 5

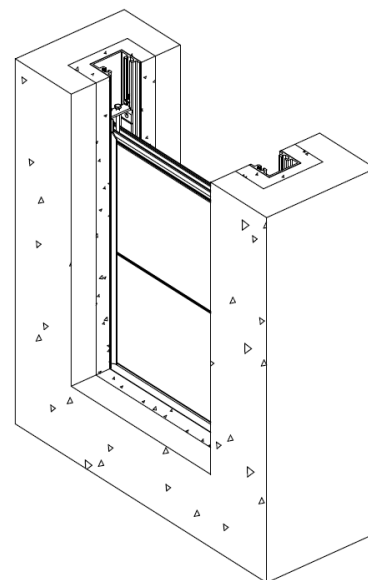

Figure 4

3.2. Face mounted (in existing channel without recesses)

Step 1: Initial assessment

- Check that the concrete wall meets the requirements described in Section 3
- Verify that all installation materials specified on the GAD are available. Anchor bolts and grout are used for this type of installation
- If the frame is made of aluminum, it is coated a special coating (Poliuretane AP-3102-E distributed by Polifluor o equivalent). If the frame is made of stainless steel, bolts that secure the vertical guides and seals must be greased (on the outside) to avoid getting bonded to the concrete

Step 2: Anchor the gate to the side of the channel

- Position the unit in the existing channel. Make sure that the gate is perfectly aligned and centered in the channel (see Figure 6)
- Install the bottom anchor bolts, and then the lateral anchor bolts (see Figure 7). All Face Mounted Channel Gates include lateral mounting

Step 3: Grout fill

Grout-fill the remaining voids (See Figure 9), both at the bottom (See Figure 8) and laterals of the gate (See Figure 7). Remember that the objective of the grout fill is twofold:

- Fill the voids between the frame, frame invert and the channel
- Make a smooth transition for water flow

CAUTION! Make sure not to get grout or any other foreign material on the gate's seals, guides or stem as this may cause leakage or damage.

MODEL

SA ALUMINUM STOP LOG

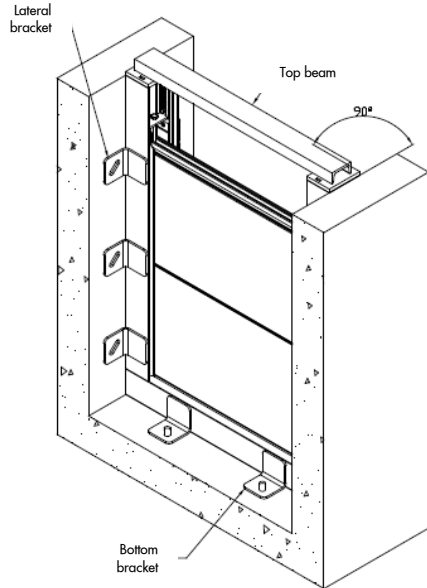

Figure 6

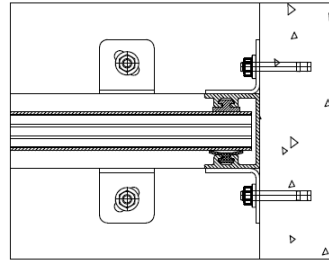

Figure 7

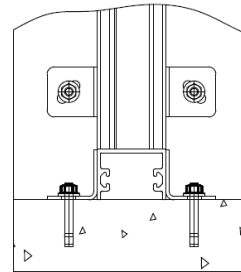

Figure 8

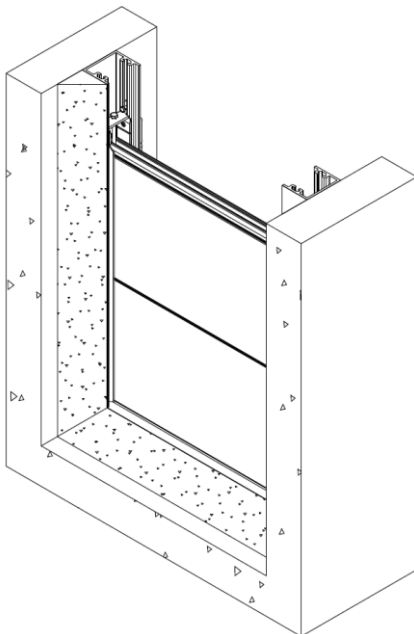

Figure 9

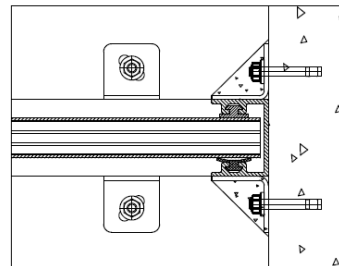

Figure 10

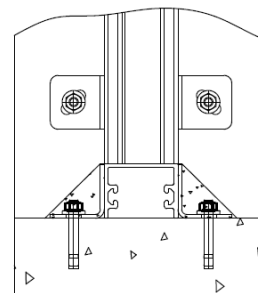

Figure 11

3.3. Wall mounted (at the end of the channel)

Step 1: Concrete construction inspection

- Check that the concrete wall meets the requirements described in Section 3
- Verify that all installation material specified on the GAD is available. The equipment is installed by means of anchor bolts. Construction sealant shall be used between the frame and the concrete wall. Alternatively, sponge EPDM rubber can be used

Step 2: Equipment pre-installation

- Present the unit to its required position and ensure that the invert of the frame is flush with the civils. Also make sure that the equipment is centered with respect to the channel opening (See Figure 12)
- Drill and install one anchor bolt on each side of the frame. After installing the first anchor bolt, and prior to drilling the hole on the other side, make sure the frame is perfectly leveled

Step 3: Construction sealant application

- Remove the unit from the wall (first remove the nuts of the anchor bolts)
- Apply construction sealant all around the perimeter of the frame. Be sure not to get sealant on the gate's seals and/or guides, as this may cause leakage or damage. (See Figure 13)
- Re-install the slide gate on the wall and tighten both anchor bolts

Step 4: Final installation

- Drill and install the rest of the anchor bolts (See Figure 14)
- CAUTION! If the unit is not completely in contact with the wall, do not over-tighten the anchor bolts. Over tightening may bend or distort the frame. If the wall flatness and levelness is according to the specified standards, the construction sealant will fill in the remaining voids
- Apply construction sealant around the frame perimeter in order to fill in any existing gap between the wall and the frame (200ml/meter) Wipe away the excess sealant to leave a smooth finish

MODEL

SA ALUMINUM STOP LOG



Figura 12



Figura 13

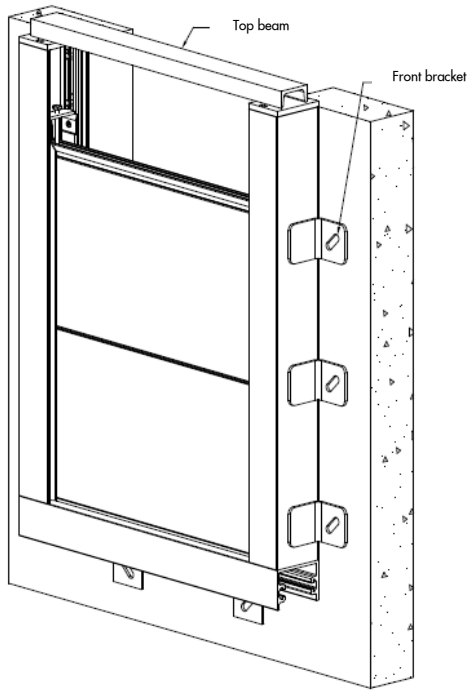

Figure 14

4. START-UP AND COMMISSIONING

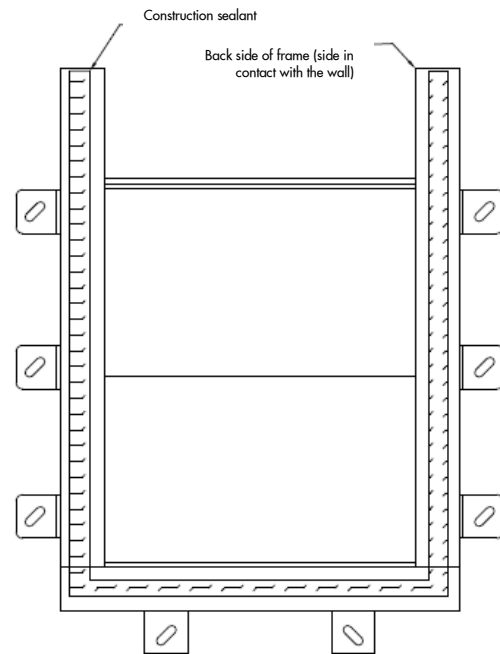
- Do not operate the gate unless it is completely necessary. Typically the plant (i.e.: waste water treatment plant) has not been finished when the commissioning occurs. Therefore, dust and dirt tends to accumulate on the seals and stems. Do not apply extra grease on the seal and/or stem until the construction of the plant has been completely finished as it forms a sticky paste with the dust. If the equipment needs to be operated previously wet the seals
- Clean the unit with clear water and make sure there are no foreign deposits or materials on the seals, guides or sealing area. Use plastic tools to remove any foreign material in order not to contaminate the stainless steel equipment

Visual Inspection

- Verify that all installation instructions defined in the GAD and the IOM manual have been followed
- Verify that the seal is in compression against the logs. Use a 0.5mm (1/32") gauge
- Embedded In concrete installation:
 - Check that the frame (or other embedded parts) has not been distorted during installation. Measure the opening width every 1 meter. The maximum deviation should be $\pm \text{width}/1000$
 - Verify that the frame invert has been embedded in concrete
- Wall mounted at the end of the channel installation:
 - Verify that there are no voids between the concrete wall and the back of the frame (open the gate and look on the sides). No light must go through the frame and the wall. Clean water can also be used to verify water tightness between the concrete wall and frame
- Face mounted in existing channel installation:
 - Check that the frame has not been distorted during installation. Measure the opening width every 1 meter. The maximum deviation should be $\pm \text{width}/1000$
 - Check that the frame has been grouted as indicated in the GAD

Field Operational Test

- Before cycling the unit, make sure there are no foreign deposits or materials on the seals, guides or sealing area. Clean the unit with clear water. Gate seals could be damaged if the area is not cleaned and coated with grease. Please refer to Section 6.1 for detailed information
- Seals shall be wetted with clear water before operating the slide gate, and stems and stem nuts shall be greased

Field Leakage Test

- Close the slide and pressurize the unit at the design water head.
- Collect the leaked water during a period of time of 10 minutes (L_{T10})
- Calculate the leakage rate: L_R (L/min and m) = $L_{T10}/(10 \cdot P)$, where P is the sealing perimeter in meters

5. OPERATION

- Seals shall be wet while operating. If the slide gate has not been used for a long period of time under dry conditions, the seals shall be wetted with clear water before operating the slide gate. Operating the gate with dry seals may damage them, and additional thrust might be required to operate the slide. Please refer to section 6.1 for detailed information about the required grease type
- The following equipment can be used to lift up the gate or logs:
 - Hand-pull: the slide or logs are equipped with handles. ORBINOX recommends the use of other methods for pull out forces higher than 50kg (110 pounds), or 25kg per person (55 pounds). Refer to the GAD for pull out force detailed information. Hand poles can be supplied for remote operation
 - External crane: the slide or logs are equipped with bull eyes to be lifted with an external crane. Optionally, a lifting device (beam) can be supplied

6. MAINTENANCE

6.1. Cleaning and lubrication

ORBINOX equipment is designed to give trouble free operation with minimum maintenance work. However, it is very important to follow the next simple maintenance activities at the defined frequency to ensure an optimum performance of the equipment.

Every six months or 100 cycles (whatever occurs first):

- Visually inspect the unit for signs of misalignment, damage or corrosion. Also, verify that all parts are in place
- Clean the unit with clear water and remove any deposits, especially on the seals and guides
- Lightly grease all moving parts
- Check the seals and make sure they are not damaged. Seals shall be replaced if damaged (see section 6.2)
- Check tightness of all unit assembly bolts and anchor bolts

Spare parts:

ORBINOX does not recommend stocking any spare parts by the owner of the equipment. If a repair part is required, please contact an ORBINOX representative and provide the following information:

- ORBINOX sales order number
- GAD number
- Project name (if applicable) and vendor's company name

Materials needed for maintenance and seal replacement:

Material	Application	Type	Recommended
Grease	Seal and guides	Silica-Gel Silicone Grease	Vercol-Verkosil G-2
	General purpose (seals, guides, threads) – Drinking water applications	ACS and NSF61 approved Silicone Grease	Dow Corning-Molykote 111
		WRAS approved Silicone-Grease	Rocol-Sapphire Aqua-sil High
Adhesive	Seal joints	Instant Adhesive	Loctite 406 or 495

6.2. Seal replacement: horizontal and bottom seal

- Each log includes two horizontal seals which are used to seal between logs. Additionally, some logs include a separate bottom seal (only for the first log, please refer to the GAD)

• Horizontal seal replacement

- Step 1: Remove the log from the frame (See Figure 15, part#2)
- Step 2: Remove the damaged seals and replace it by the new ones (See Figure 16, part#1). Add general 12urpose Loctite to secure the seal in position

• Bottom seal replacement

- Step 3: Remove the first log from the frame
- Step 4: Remove and replace the bottom seal (see Figure 18, part#3). Some logs include bolted bottom seals (See Figure 17, part#4) by means of a stainless steel retainer (See Figure 17, part#5)

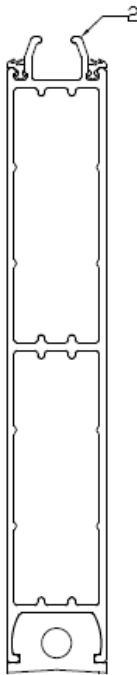

Figure 15

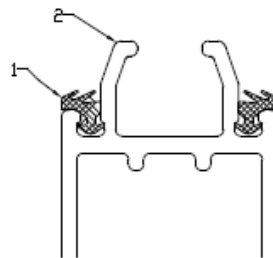

Figure 16

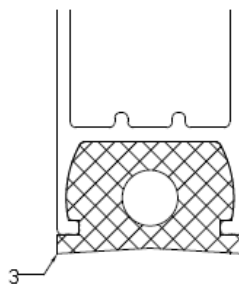

Figure 18

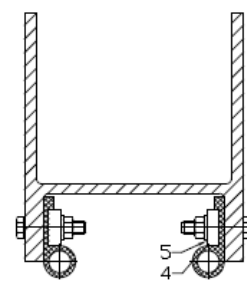

Figure 17

6.3. Seal replacement: vertical seal

- Remove all logs from the frame
- Remove the “Seal and guide Locking System”
- Remove the vertical seals and replace by the new ones. For stainless steel frames, the seals are secured with stainless steel retainers
- Secure the Locking System in position, making sure the seal is in compression against the bottom part of the frame

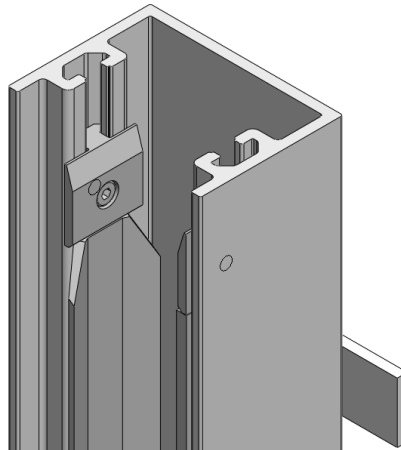
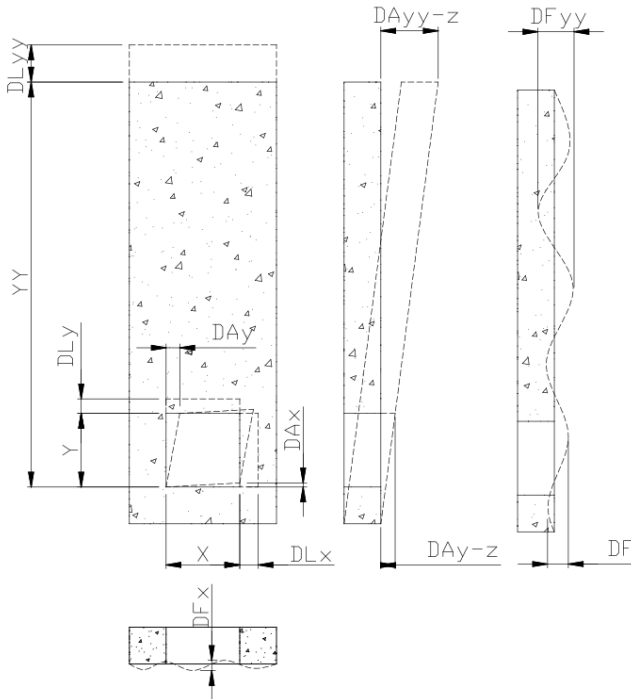

Figure 19

7. TROUBLESHOOTING

SYMPTOM	CAUSE	SOLUTION
<ul style="list-style-type: none"> LEAKAGE (Between frame and concrete wall, for Face Mounted In Existing Channel Configuration) 	<ul style="list-style-type: none"> Concrete Wall does not meet the required tolerance specification 	<ul style="list-style-type: none"> Uninstall unit, repair the concrete wall and re-install the unit
	<ul style="list-style-type: none"> Gaps between frame and face of wall due to miss-application of grout fill 	<ul style="list-style-type: none"> Grout Fill remaining gaps
<ul style="list-style-type: none"> LEAKAGE (Leakage between frame and concrete wall, for Wall Mounted Configuration). 	<ul style="list-style-type: none"> Concrete Wall does not meet the required tolerance specification 	<ul style="list-style-type: none"> Uninstall unit, repair the concrete wall and re-install the unit
	<ul style="list-style-type: none"> Insufficient construction sealant (refer to the GAD) 	<ul style="list-style-type: none"> Uninstall the unit, clean the concrete wall, and apply new construction sealant (refer to the GAD for type and quantity).
	<ul style="list-style-type: none"> Loose anchor bolts Incorrect anchor bolts (refer to the GAD) 	<ul style="list-style-type: none"> Tighten anchor bolts Install appropriate anchor bolts (refer to the GAD for type and quantity)
<ul style="list-style-type: none"> LEAKAGE (through the bottom seal or between logs) 	<ul style="list-style-type: none"> Foreign deposits trapped in between the frame invert and bottom seal or between logs 	<ul style="list-style-type: none"> Open slightly the log(s) and remove all foreign deposits. Check if seals have been damaged.
	<ul style="list-style-type: none"> Damaged bottom and/or horizontal seal 	<ul style="list-style-type: none"> Replace seal
	<ul style="list-style-type: none"> Not enough compression between logs 	<ul style="list-style-type: none"> Adjust log locking system device
<ul style="list-style-type: none"> EXCESSIVE FORCE REQUIRED FOR OPERATION 	<ul style="list-style-type: none"> Dry seals 	<ul style="list-style-type: none"> Wet seals

8. ANNEX: CIVIL WORK TOLERANCES



- X: opening width
- Y: opening height
- YY: invert to coping distance
- DLx: linear deviation (with respect to X dimension)
- DLy: linear deviation (with respect to Y dimension)
- DLyy: linear deviation (with respect to YY dimension)
- DAX: angular deviation (with respect to X dimension)
- DAY: angular deviation (with respect to Y dimension)
- DAY-z: angular deviation (with respect to Y dimension in z direction)
- DAXy-z: angular deviation (with respect to YY dimension in z direction)
- DFxx: flatness deviation (with respect to X dimension)
- DFyy: flatness deviation (with respect to Y dimension)
- DFyy: flatness deviation (with respect to YY dimension)

Deviations shall be within the tolerances defined in DIN 18202:

Deviation	Maximum deviation
Linear deviation (DLx, DLy, DLyy):	DIN 18202, table 1, group 2 (for DLx and DLy) DIN 18202, table 1, group 5 (for DLyy)
Angular deviation (DAX, DAY, DAY-z, DAXy-z)	DIN 18202, table 2
Flatness deviation (DFxx, DFyy, DFyy)	DIN 18202, table 3, group 7

The following tables show the tolerances defined in DIN 18202:

DIN 18202 TABLE 1	Group	Applicable to	Max. admissible deviation (mm) for target size (m)					
			≤ 1	> 1 ≤ 3	> 3 ≤ 6	> 6 ≤ 15	> 15 ≤ 30	> 30
Linear deviation	Group 2	DLx, DLy	+10	+12	+16	-	-	-
	Group 5	DLyy	+10	+16	+16	+20	+30	+30

DIN 18202 TABLE 2	Group	Applicable to	Max. admissible deviation (mm) for target size (m)						
			≤ 0,5	> 0,5 ≤ 1	≥ 1 < 3	≥ 3 < 6	≥ 6 < 15	≥ 15 ≤ 30	≥ 30
Angular deviation		DAX, DAY, DAY-z, DAXy-z	3	6	8	12	16	20	30

DIN 18202 TABLE 3	Group	Applicable to	Max. admissible deviation (mm) for target size (m)				
			< 0,1	≥ 0,1 < 1	≥ 1 < 4	≥ 4 < 10	≥ 4 < 10
Flatness deviation	Group 7	DFxx, DFyy, DFyy	2	3	8	15	20

9. ENVIRONMENTAL CONSIDERATIONS

- The packaging is made from environmentally friendly materials. Dispose of the packaging through the available recycling channels
- The valve is designed and manufactured with materials that can be recycled by specialised recycling firms. Once the life of the product is expired, you have to consider a proper disposal of the product in order to prevent any negative impact on the environment and allows for the recycling of valuable commodities
- Please follow the local environmental rules in your country for proper disposal