



AVK SERIES 21/89 RESILIENT SEATED GATE VALVES INSTALLATION, OPERATION & MAINTENANCE MANUAL



Instruction for use

Thank you for selecting an AVK product. With correct use, the product is guaranteed to deliver a long and reliable service. This manual has been prepared to assist you with the installation, operation and maintenance of the valve to the maximum efficiency. For ease of reference, it has been divided into sections covering all aspects of use, and it is in the users best interests to read it and ensure that it is fully understood.



Health and Safety

It is always recommended that wherever work is being carried out on a valve that the valve is fully depressurised prior to carrying it out, and for the convenience draining of the line may be beneficial.

It is essential that the user of the valve is aware of the weight of the components and/or assemblies that must be handled and manipulated during installation and maintenance. It is the users responsibility to ensure that safe working practices are followed at all times.

Whenever AVK products are installed, operated, or maintained, it is essential that the staff that undertake these operations be adequately trained. The hazards of pressurised liquids and gases can be severe, and it is the responsibility of the users to ensure that trained, competent staff undertake these duties. This manual has been designed to assist, but it can never fully replace quality training in the workplace. AVK technical staff will always be available to answer any questions relating to specific problems that may not be covered by this manual.

AVK products are designed and manufactured to be fit for purpose, and to a high and reliable standard. This provides a safe product with minimum risk to health when used correctly for the purpose for which it was designed. However, this assumes that the equipment is used and maintained in accordance with the manual, and the user is advised to study this manual, and to make it available to all staff that may need to refer to it.

AVK cannot be held responsible for any incidents arising from incorrect installation, operation or maintenance. The responsibility for this must rest wholly with the user.

AVK SERIES 21/89 RESILIENT SEATED GATE VALVES INSTALLATION, OPERATION & MAINTENANCE MANUAL

1. Introduction

AVK series **21/89** gate valves are available in DN50 to DN400. The valve has a full and straight bore corresponding to the nominal diameter and can be installed independent of the flow direction. To keep the advantage of the full and straight bore vertical installation is recommended, however, flow/pressure limitations outlined below should be observed.

The valves are 100% factory tested hydrostatically.

IT IS IMPORTANT TO STATE OPERATING TEMPERATURE, PRESSURE, MEDIUM AND OPERATING CONDITIONS WITH ENQUIRIES/ORDERS, SO THE MOST SUITABLE VALVE WILL BE SUPPLIED FOR YOUR SPECIFIC PURPOSE.

Materials:

Body, bonnet, yoke, adaptor flange, gland follower	Ductile iron, GGG-50, to DIN 1693 (BS 2789 grade 500 - 7)
Handwheel	Grey iron
Coating	Electrostatically applied epoxy resin to DIN 30677 - Internally and externally, according to GSK specifications
Stem	Stainless steel, DIN X 20 Cr 13
Pin	Stainless steel, A2
O-rings	NBR
Wedge nut, stem nut	Dezincification resistant brass, CZ 132 to BS 2874
Gland, bushing	Polyamid
Wedge	Ductile iron, GGG-50, core fully encapsulated with EPDM rubber with integral wedge nut of dezincification resistant brass, CZ 132 to BS 2874
Bonnet bolts	Galvanized steel, 8.8, sealed with hot melt
Stud bolts, washer and nut	Galvanized steel, 8.8
Bonnet gasket	EPDM
Anti friction washer	RG5



AVK SERIES 21/89 RESILIENT SEATED GATE VALVES INSTALLATION, OPERATION & MAINTENANCE MANUAL

Component list

- | | | |
|-------------------|----------------------|--------------------------|
| 1. Stem | 10. Bonnet bolt seal | 19. Handwheel |
| 2. Yoke | 11. Bonnet bolt | 20. Adaptor flange |
| 3. Gland follower | 12. Bonnet gasket | 21. Anti friction washer |
| 4. Gland | 13. Wedge nut | 22. Actuator inset bolt |
| 5. Stem seal | 14. Pin | 23. Stud bolt |
| 6. Bushing | 15. Rubber coating | 24. Nut |
| 7. O-ring | 16. Wedge body | 25. Washer |
| 8. O-ring | 17. Valve body | |
| 9. Bonnet | 18. Stem nut | |

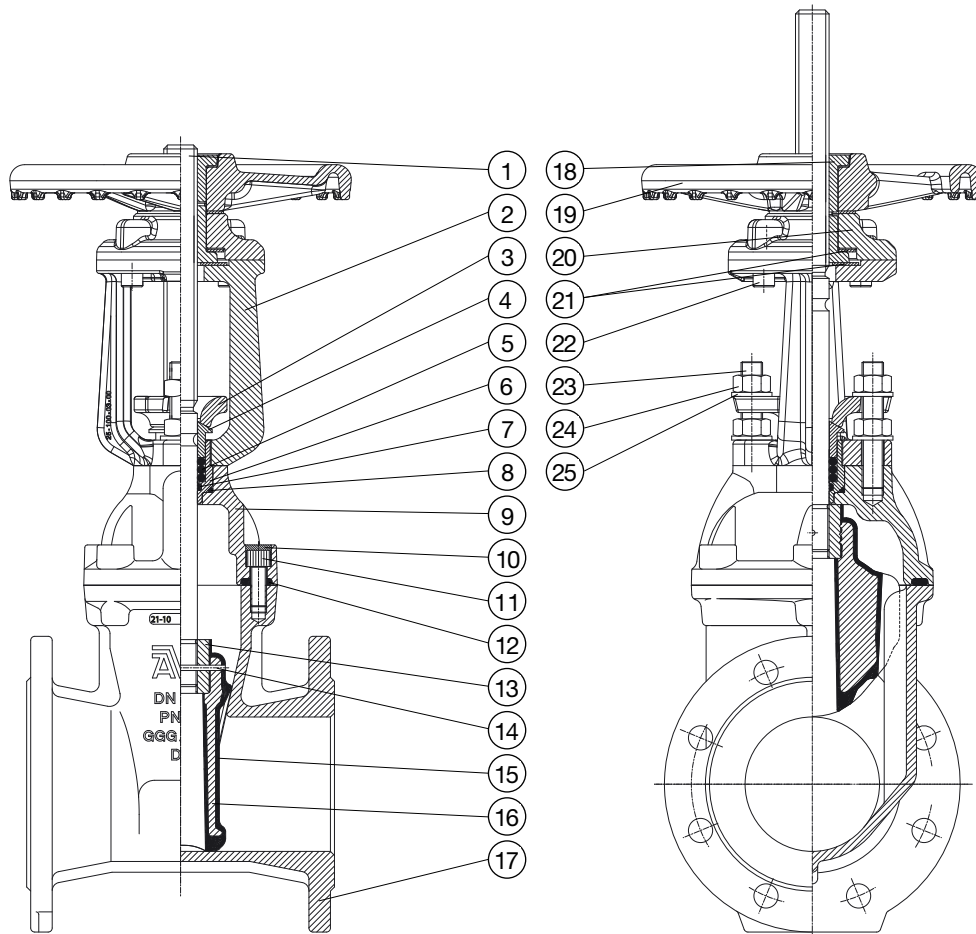

AVK SERIES 21/89 RESILIENT SEATED GATE VALVES INSTALLATION, OPERATION & MAINTENANCE MANUAL

2. Installation

- When installing the gate valves, ensure that the seats and the flange faces are clean.
- When valves are provided with lifting lugs, plates or eye nuts, these must be used to lift the valve.
- To ensure adequate sealing it is important to select the correct type of gasket for the medium concerned, gaskets with the correct flange size must be used.
- Place valve between pipe flanges, and insert the bolts.
- Tighten bolts loosely.
- Tighten bolts in a diagonal sequence to ensure flanges are pulled parallel.
- Finally tighten bolts to correct torque levels as recommended.

2.1. Bolts

2.1.1 Bolt Tightening Sequence for flanges using:

The following tables indicate bolt tightening based on the number of flange bolts.

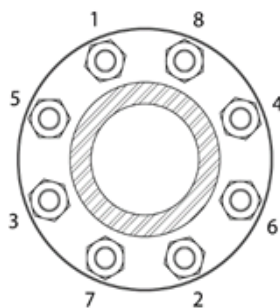

8 Bolts

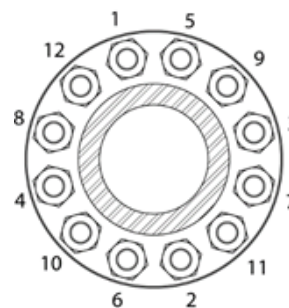

12 Bolts

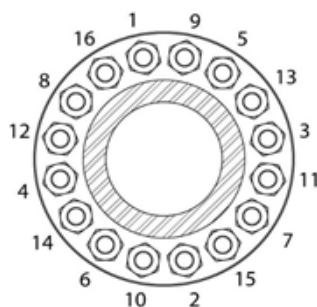

16 Bolts

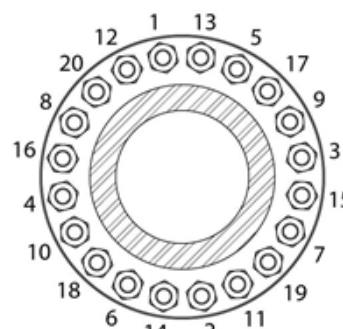

20 Bolts

2.2. Gland Follower

Prior to pressurisation check gland follower nuts are finger tight. After pressurisation operate valve and check for weeping. Nip nuts (24) until weeping stops.

Note: If nuts are excessively tightened torque operation of the valve is increased dramatically.

3. Operation

Series 21/89 valves are suitable for use with clean water or neutral liquids up to 70°C. Minimum liquid temperature must be above freezing. Insulation is essential for external temperatures on 0°C to - 10°C. The valves are operated manually by handwheel. Design pressure PN10/16.

AVK SERIES 21/89 RESILIENT SEATED GATE VALVES INSTALLATION, OPERATION & MAINTENANCE MANUAL

4. Maintenance

4.1 Replacement of Handwheel

Component list

2. Yoke	16. Wedge body	18. Stem nut	21. Anti friction washer	24. Nut
3. Gland Follower		19. Handwheel	22. Actuator insex bolt	25. Washer
		20. Adaptor flange	23. Stud bolt	

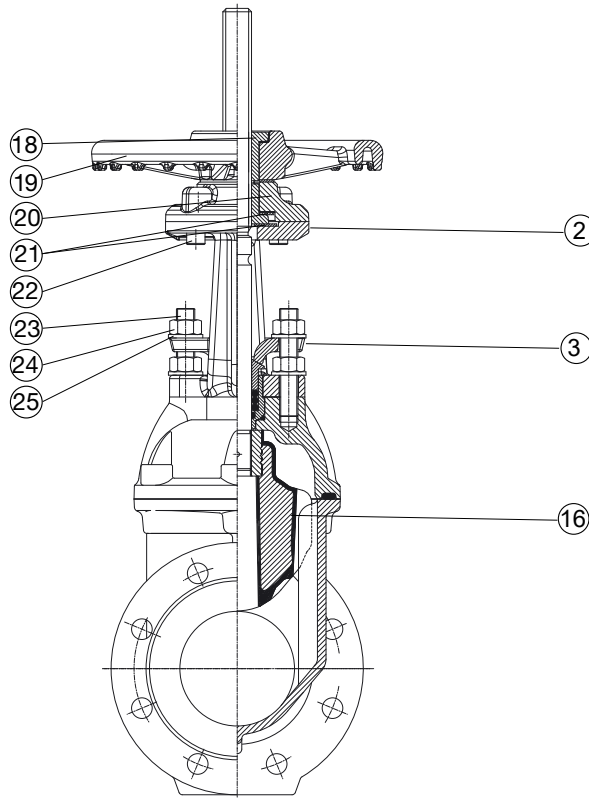

- a) Remove nuts (24) from studs (23).
 - b) Lift gland follower (3) up and remove nuts (24) and washers (25). Loosen and remove actuator insex bolt (22). Then turn handwheel (19) clockwise until upper stem nut (18) comes off assembly.
 - c) Place top half of stem nut (18) into new handwheel (19) and align with hexagon. The stem nut should fit neatly inside the recess in the top of the handwheel.
Place the stem nut and handwheel assembly on top of yoke/anti friction washer assembly and align top half of stem nut with the bottom half via the lugs.
- Note: The stem nuts will only go together one way as the lugs are different widths.**
- d) Thread handwheel (19) onto stem anti clockwise making sure that the adaptor flange (20) bolt holes line up with the yoke actuator insex bolts (22) with no interference.
 - e) Thread handwheel (19) onto stem until the adaptor flange (20) sits flush on top of the yoke (2) with the wedge (16) raised from the seat position.
 - f) Lift gland follower (3) up and place onto studs (23) to secure gland follower (3) in place.
 - g) Tighten nuts (22) that secure adaptor flange (20) to yoke (2), lower gland follower over studs (23) and place one washer (25) on top of each stud.
 - h) Place a small amount of Loctite 680 Threadlocker onto the nuts (24) that secure the gland follower (3).
 - i) Place nuts (24) onto studs (23) and tighten evenly to fingertight.
 - j) After pressurisation operate valve and check for weeping. Nip nuts (24) until weeping stops.

Important: Ensure that valve operates smoothly and freely when opening and closing.

AVK SERIES 21/89 RESILIENT SEATED GATE VALVES INSTALLATION, OPERATION & MAINTENANCE MANUAL

4.2 Replacement of Stem Seal (5)

Component list

1. Stem	10. Bonnet bolt seal	19. Handwheel
2. Yoke	11. Bonnet bolt	20. Adaptor flange
3. Gland follower	12. Bonnet gasket	21. Anti friction washer
4. Gland	13. Wedge nut	22. Actuator insex bolt
5. Stem seal	14. Pin	23. Stud bolt
6. Bushing	15. Rubber coating	24. Nut
7. O-ring	16. Wedge body	25. Washer
8. O-ring	17. Valve body	
9. Bonnet	18. Stem nut	

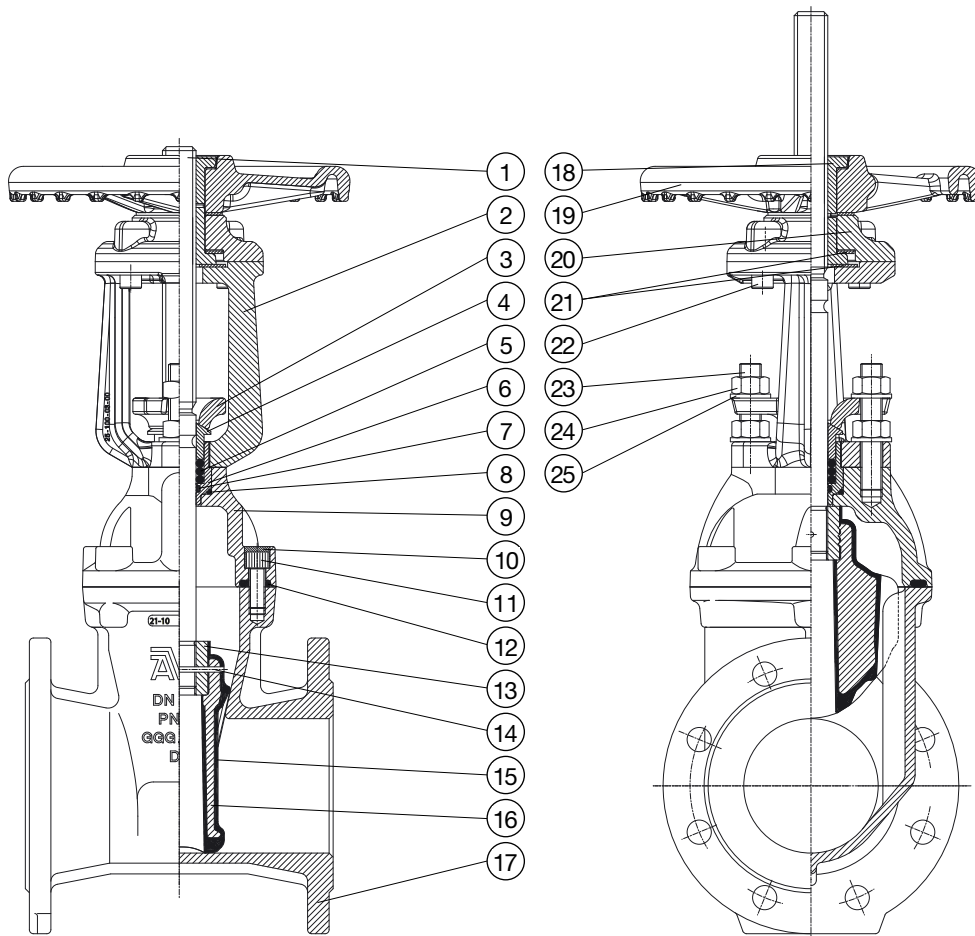

WARNING: To perform the following steps, be sure the water main supply line has been shut off, and that the pressure has been bled off! Also provide sufficient clearing around the valve so that no soil or debris may fall into it.

- Remove the two gland nuts (24) and washers (25). Lift the gland follower (3) up off of the stud bolts (23).
- Lift the gland (4) to access the stem seal (5). **NOTE:** These stem seals are split-type. When replacing them, ensure that the splits **DO NOT** align. Rotate the splits at approximately 90 degree intervals.
- Reverse steps a) and b) for re-assembly.

Repressurise the system. At this time, if there is a leak around the gland be sure that the upper gland follower / yoke nuts are screwed down evenly on the stud bolts. Tighten the nuts ¼ turn each until the leak stops.