



AVK SERIES 756 BUTTERFLY VALVES DOUBLE ECCENTRIC INSTALLATION, OPERATION & MAINTENANCE MANUAL

Instruction for use

Thank you for selecting an AVK product. With correct use, the product is guaranteed to deliver a long and reliable service. This manual has been prepared to assist you with the installation, operation and maintenance of the valve to the maximum efficiency. For ease of reference, it has been divided into sections covering all aspects of use, and it is in the users best interests to read it and ensure that it is fully understood.

Health and Safety

It is always recommended that wherever work is being carried out on a valve that the valve is fully depressurised prior to carrying it out, and for the convenience draining of the line may be beneficial.

It is essential that the user of the valve is aware of the weight of the components and/or assemblies that must be handled and manipulated during installation and maintenance. It is the users responsibility to ensure that safe working practices are followed at all times.

Whenever AVK products are installed, operated, or maintained, it is essential that the staff that undertake these operations be adequately trained. The hazards of pressurised liquids and gases can be severe, and it is the responsibility of the users to ensure that trained, competent staff undertake these duties. This manual has been designed to assist, but it can never fully replace quality training in the workplace. AVK technical staff will always be available to answer any questions relating to specific problems that may not be covered by this manual.

AVK products are designed and manufactured to be fit for purpose, and to a high and reliable standard. This provides a safe product with minimum risk to health when used correctly for the purpose for which it was designed. However, this assumes that the equipment is used and maintained in accordance with the manual, and the user is advised to study this manual, and to make it available to all staff that may need to refer to it.

AVK cannot be held responsible for any incidents arising from incorrect installation, operation or maintenance. The responsibility for this must rest wholly with the user.

AVK SERIES 756 BUTTERFLY VALVES DOUBLE ECCENTRIC INSTALLATION, OPERATION & MAINTENANCE MANUAL

1. Introduction

Manufactured from Ductile Iron the series 756 double eccentric butterfly valve incorporates a positively retained resilient disc seal and either an integral or replaceable body seat. The valve is mainly designed for use with water, sewage and neutral liquids, but may also be used in other duties after contacting AVK. The integral seat design is for use on water treatment and water distribution lines where on occasions buried service is required.

The valve has three unique attributes; reduced weight, greater strength and lower torque.

Materials:

Castings (body)
Ductile Iron

Coating
Fusion bonded epoxy (FBE)

Shaft
Stainless Steel

Bushings
Bronze

Refer to datasheet for specific information



AVK SERIES 756 BUTTERFLY VALVES DOUBLE ECCENTRIC INSTALLATION, OPERATION & MAINTENANCE MANUAL

Component list

- | | | | |
|-----------------------------|--------------------|-------------------|----------------------------|
| 1. Key | 10. Drive pin | 19. Washer | 28. Screw |
| 2. Valve shaft | 11. O-ring | 20. Screw | 29. Screw |
| 3. Seal housing | 12. Plug | 21. Screw | 30. O-ring |
| 4. O-ring | 13. Body | 22. Axial bearing | 31. Bolt |
| 5. O-ring | 14. Disc | 23. Screw | 32. Washer |
| 6. Self-lubricating bearing | 15. Security plate | 24. End plate | 33. O-ring |
| 7. Disc cover | 16. Screw | 25. Gasket | 34. Seal retaining ring |
| 8. Disc cover gasket | 17. Screw | 26. Stub shaft | 35. Disc seal |
| 9. O-ring | 18. Nut | 27. Safety key | 36. Gearbox with handwheel |

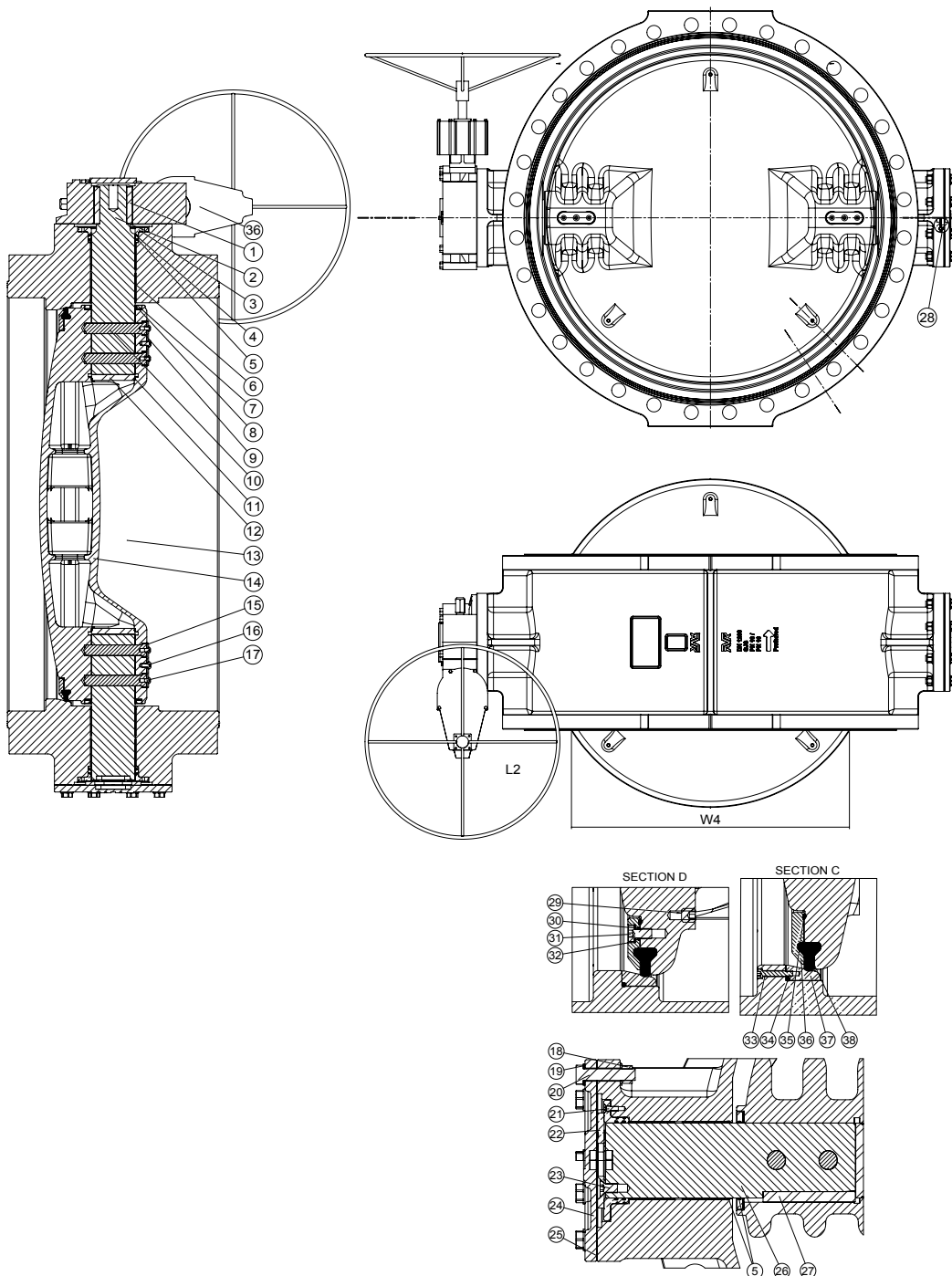

AVK SERIES 756 BUTTERFLY VALVES DOUBLE ECCENTRIC INSTALLATION, OPERATION & MAINTENANCE MANUAL

2. Installation

- When installing the valve ensure that the seat and flanges are clean.
- Valves should be installed in the horizontal position wherever possible.
- When installed in close proximity of centrifugal pumps, orientation of the pump may require vertical orientation.
- When lifting valves use lifting lugs/points provided.
- Flange gaskets are required.
- Place valve between pipe flanges and insert bolts.
- Tighten bolts loosely.
- Tighten bolts in a diagonal sequence to ensure flanges are pulled parallel.
- Finally, tighten bolts to correct torque as recommended in WSA 109.

DN	Bolts	Qty
600	M27	16
700	M27	20
750	M30	20
800	M33	20
900	M33	24
1000	M33	24
1200	M33	32

3. Operation

Design Constraints

Please consider the following points when selecting and installing your valve:

- Consideration should be given at the design stage where valves will be located to give access for operation, adjustment, maintenance and repair.
- If a valve is installed less than 6 diameters downstream of an elbow or tee etc., it may experience very high-localised turbulence. Therefore if possible installation in this area should be avoided.
- Valves must be provided with adequate support. Adjoining pipework must be supported to avoid the imposition of pipeline strains on the body that may impair its performance.
- Heavy valves may need independent support or anchorage.
- Recommended maximum average flow velocity on normal and wash out duties is 5m/sec.

Storage

- If valves are to be stored in the open for some time, protection should be provided to keep the valves clear of sand and mud.
- Resilient seats should be protected. It is usual practice to smear the rings with a WRc (drinking water approved) listed grease which is suitable for use with potable water and compatible with EPDM rubber.
- Valves may be stacked and the upper open end covered with waterproof material and boarded over.
- Gearboxes and actuators should be protected against water and damage.
- The valve should be slightly open to prevent unnecessary loading on the seal.
- They should not be stored in dust laden or saline environments.
- They should be stored at ambient temperature.

Handling

- When unloading valves it is preferable to lift by means of shackles in the holes provided in the valve body.
- If it is more convenient, slings may be used around the shaft bosses, providing no contact is made with the gearbox, actuator or indicator.
- The gearbox or actuator should never be used as a lifting point.
- Valves should be lowered gently onto wooden battens placed on firm ground, clear of mud and water.

AVK SERIES 756 BUTTERFLY VALVES DOUBLE ECCENTRIC INSTALLATION, OPERATION & MAINTENANCE MANUAL

4. Maintenance

4.1 Seal Renewal

Component list

1. Key	10. Drive pin	19. Washer	28. Screw
2. Valve shaft	11. O-ring	20. Screw	29. Screw
3. Seal housing	12. Plug	21. Screw	30. O-ring
4. O-ring	13. Body	22. Axial bearing	31. Bolt
5. O-ring	14. Disc	23. Screw	32. Washer
6. Self-lubricating bearing	15. Security plate	24. End plate	33. O-ring
7. Disc cover	16. Screw	25. Gasket	34. Seal retaining ring
8. Disc cover gasket	17. Screw	26. Stub shaft	35. Disc seal
9. O-ring	18. Nut	27. Safety key	36. Gearbox with handwheel

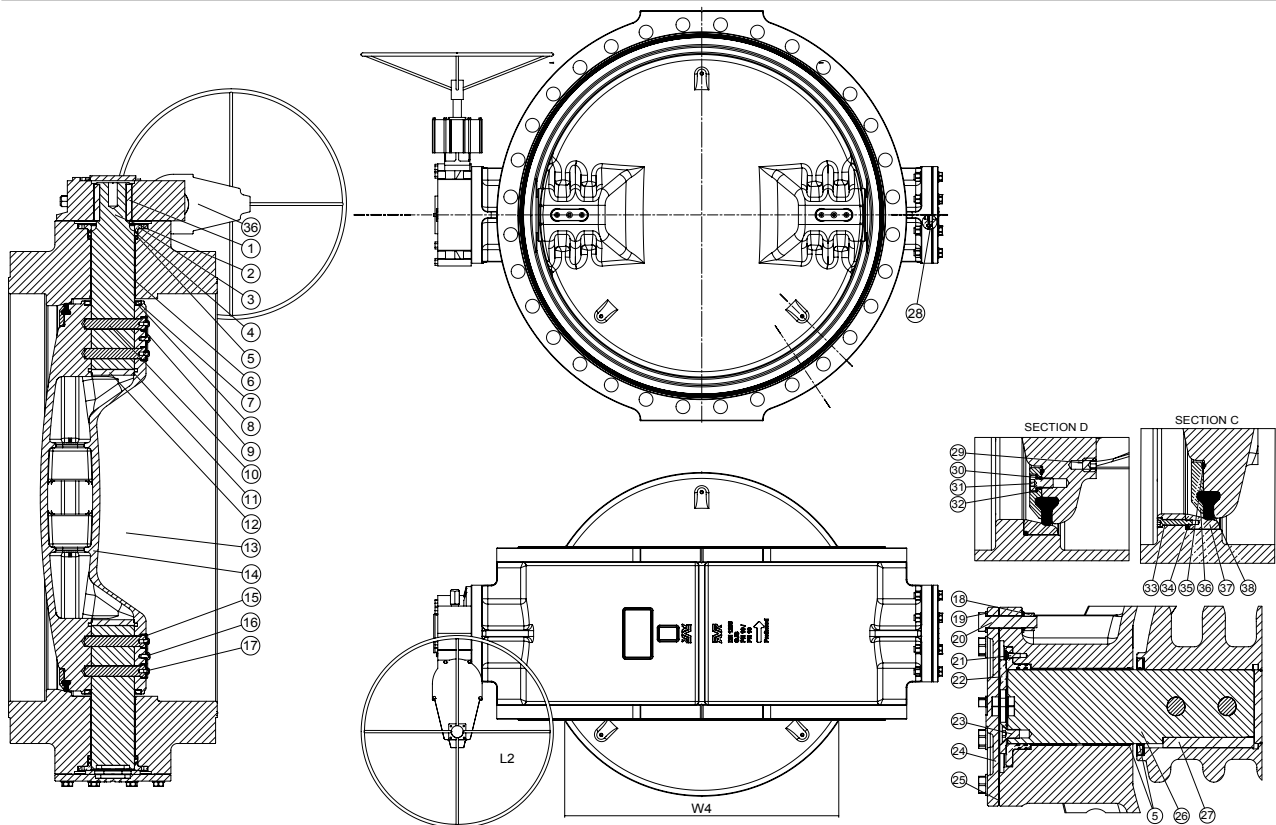

- Move the door to the vertical position and unscrew the socket screws each side of the shaft using a hexagon or square key (Note: on larger valves the retaining ring is segmented for ease of handling).
- Move the door back to the horizontal position and unscrew the remaining socket screws from the ring.
- Remove the seal (35) from under the retaining ring (34) or segments.
- The new resilient seal will require drilling using the retaining ring as a template. (Note: on larger valve replacements, resilient seals will be supplied as an extruded length and will require to be made to a complete ring on site).
- When drilling the seal, use a drill size that is the same as the size of the retaining screw tapping drill so that the screws thread themselves into the rubber to maintain pressure tightness and prevent turning.
- Once the seal and retaining ring have been replaced (with segments in correct sequence), the screws should be inserted and tightened evenly and without excessive pressure to avoid spreading the rubber.
- It is advisable, though not essential, to smear the exposed part of the rubber seal with a suitable WRc (drinking water approved) listed grease.
- Using feeler gauges, check for fluid tightness around the periphery of the seal.
- Should the valve leak, a slight adjustment of the closed stop will in most cases provide the tight seal desired, i.e. slacken the lock nut and turn the stop screw half to one turn anticlockwise.